

KR730 Roller Registration Conveyor



Register a wide range of product efficiently and conveniently with the KR 730 Roller Registration Conveyor.

The KR730 adjusts quickly and easily to accommodate a wide range of material from small 3" x 3" single sheet up to 15" x 15" books. The unique non-angled infeed and outfeed rollers maintain registration integrity.

The unique design of the KR730 allows you to configure it to match your space requirements. Product can exit right, left or straight through. Changeover between exit positions is quick and easy.

The versatility of the KR730 separates it from the competition. Invest in the KR730 and find out how a little versatility can make a big difference in your productivity.

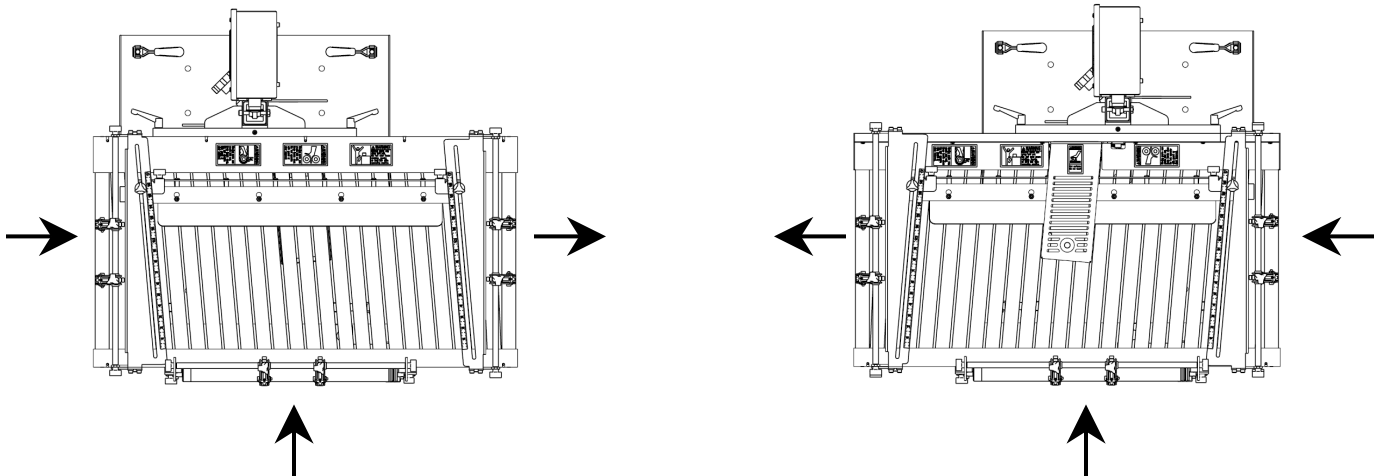
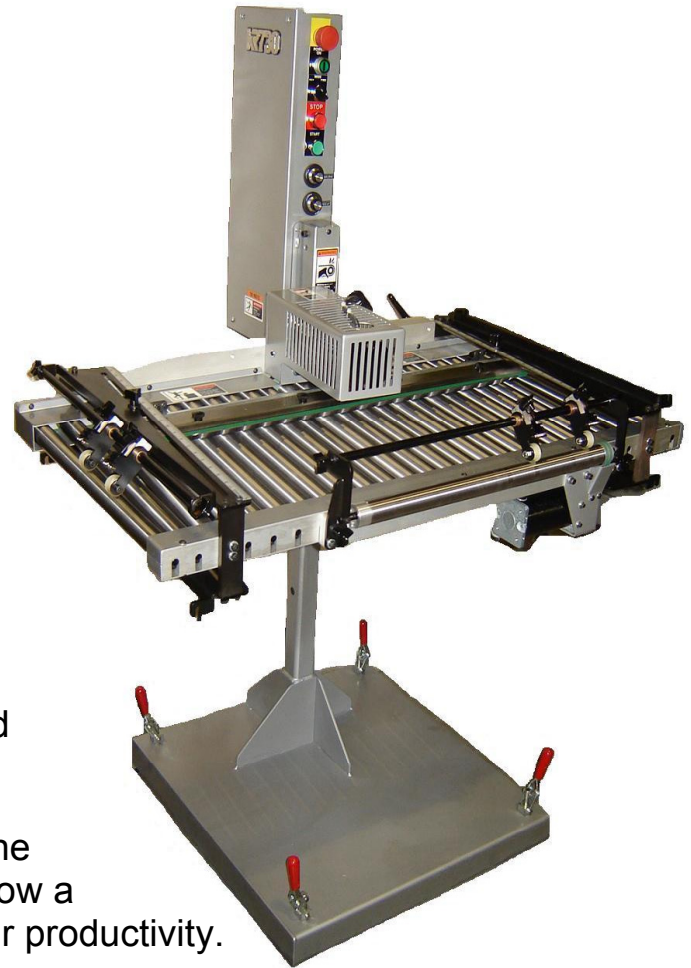

A wide product size range and the ability to deliver product registered inline, to the right or left make the KR 730 one of the most versatile roller registration conveyors on the market.

KR 730 Roller Registration Conveyor



**General Specifications

◆ **Electrical Requirements:** 120VAC, 1PH, 8A, 50-60Hz

◆ **Physical Dimensions:**

Length:	38.25" (97.2cm)
Width:	34" (86.4cm)
Height:	58.5" (148.6cm)
Max Conveyor Height:	37.5" (95.2cm)
Minimum Conveyor Height:	24.0" (60.94cm)
Max Incline/Decline Angle:	16 Degrees
Max Height Difference:	10" (25.4cm)

◆ **Roller Maximum Speed** 650'/min (220m/min)

◆ **Product Specifications:**

Minimum:	3" x 3" (76.2mm x 76.2mm)
Maximum:	15" x 15" (381mm x 381mm)
Minimum Thickness:	.004" (.102mm)
Maximum Thickness:	.25" (6.4mm)

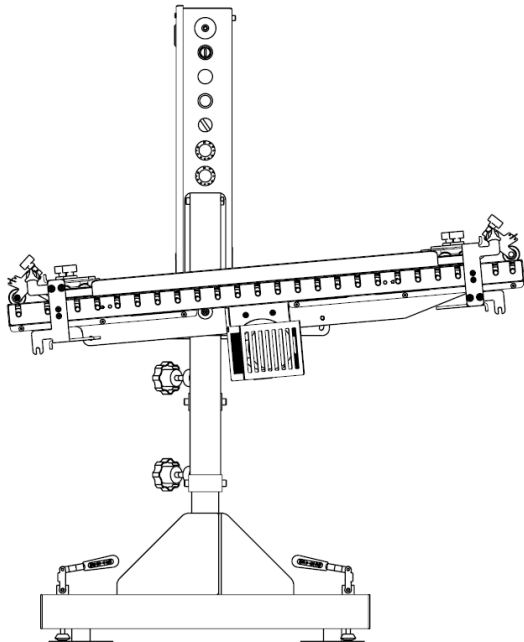

The KR730 conveyor is shown being used as an in-line incline registration conveyor.

Features

- ◆ First angled roller registration table to include non-angled transfer rollers on the infeed and outfeed to ensure the product stays registered after leaving the conveyor.
- ◆ Smaller diameter rollers transport large and small product sizes even with large length to width ratios.
- ◆ Super fast set-up times with **no tools required**.
- ◆ Accurately control the speed of the in-coming product with the speed-up roller to ensure proper delivery for registration every time.
- ◆ Adjustable product transfer pinch rollers help transfer product at critical points and ensure product stays registered.
- ◆ Consistently register product in a 90 degree or straight through product flow configuration.
- ◆ Quickly convert conveyor from "left to right" to "right to left" product flow by rotating the table 180 degrees **without tools**.
- ◆ Easily transport product from up to 10 inches in height difference by using the conveyor as an incline or decline conveyor while registering your product.
- ◆ Height adjustments are made quick and easy by the assistance of a powerful gas spring.
- ◆ Move easily in place with four swivel casters and foot operated floor jacks.
- ◆ Durable unique belt drive system keep things quiet and is easy to maintain with super quick belt changes to greatly minimize down time.
- ◆ A quiet ball skid-bar registers thin product reliably.
- ◆ Individually driven cones skid-bar (optional) to handle heavy products.
- ◆ Two variable high-speed DC motors.
- ◆ Control panel is mounted high for maximum visibility and ease of use.
- ◆ Up stream "Stop-Out" and down stream "Stop-In" interface.

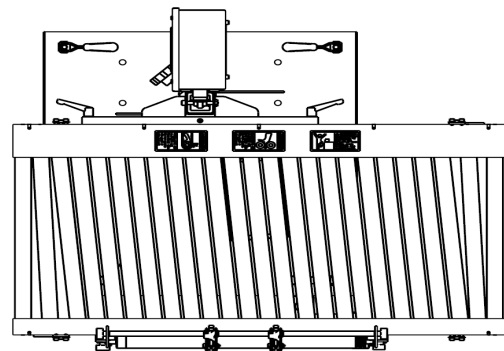

The unique infeed and outfeed rollers are not angled to ensure the product stays registered after leaving the conveyor.

**Specifications subject to change without notification